

MAXXDRIVE® XT
Right-Angle Gear Units
Industrial Gear Units

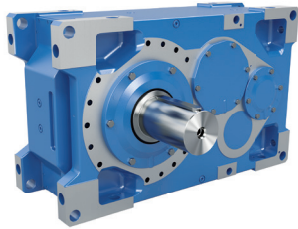

NORD DRIVESYSTEMS Group



Industrial gear units

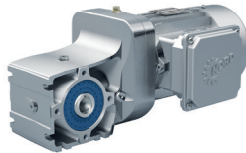

Geared motors



Frequency inverters and motor starters

- ▶ Headquarters and technology centre in Bargteheide near Hamburg.
- ▶ Innovative drive solutions for more than 100 branches of industry.
- ▶ 7 production locations with cutting edge technology produce gear units, motors and drive electronics for complete drive systems from a single source.
- ▶ NORD has 51 subsidiaries in 36 countries and further sales partners in more than 50 countries, providing local stocks, assembly centres, technical support and customer service.
- ▶ More than 4,000 employees throughout the world create customised solutions.



Headquarters in Bargteheide



Gear unit production

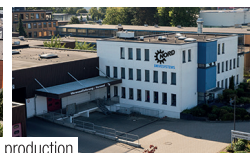

Inverter production



Motor production



Production and assembly



Motor mounting



Reliable drive units with maximum thermal and mechanical load capacities with greatly increased bearing life are necessary in material handling technology for transporting bulk materials.

With its latest development, the MAXXDRIVE® XT gear unit series, NORD has launched an a high performance drive system, which uniquely meets all of these requirements.

Characteristics / Performance

- ▶ Developed for maximum thermal power
- ▶ Maximum size axial fan and optimized cooling air flow
- ▶ Considerably increased housing surface for effective heat transmission
- ▶ No external cooling required
- ▶ Externally accessible backstop
- ▶ Variable installation / mirror image design
- ▶ Universal, symmetrical housing

Ultimate thermal limit power

To achieve the maximum thermal load capacity, the perfect contour of the gear unit housing was developed with the aid of CFD analysis and the air flow of the integrated axial fan was optimized to achieve a highly efficient cooling effect.

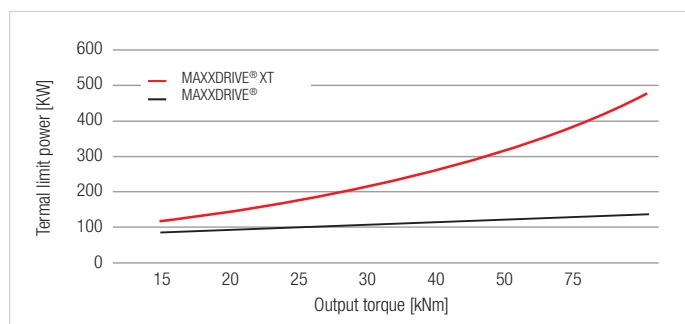

Available sizes and speed ratios

Type	Speed ratio	Output torque	Thermal limit power	Hollow shaft	Solid shaft
	[-]	[Nm]	[kW] *	d [mm]	d [mm]
SK 5217	6.3 – 22.4	15,000	max. 347	105	120
SK 6217	6.3 – 22.4	20,000	max. 439	105	120
SK 7217	6.3 – 18.0	25,000	max. 493	125	140
SK 8217	6.3 – 20.0	30,000	max. 574	125	140
SK 9217	6.3 – 18.0	40,000	max. 541	160	160
SK 10217	6.3 – 18.0	50,000	max. 829	160	160
SK 11217	7.1 – 22.4	75,000	max. 877	170	170

* max. power at 1,500 rpm and 20 °C ambient temperature

MAXXDRIVE® XT Right-Angle Gear Units

MAXXDRIVE® XT product options

- ▶ Integrated axial fan with protective cover on the drive shaft
- ▶ Foot mounted version (solid output shaft)
- ▶ Flange version (output flange)
- ▶ Shaft mounted (hollow output shaft with parallel key or shrink disc)
- ▶ Fixing element, protective cover, torque support
- ▶ Externally accessible backstop
- ▶ Monitoring sensors (temperature, vibration, speed, oil level, etc.)
- ▶ Auxiliary drive (Gearmotor)
- ▶ IEC/NEMA adapter
- ▶ Oil heater

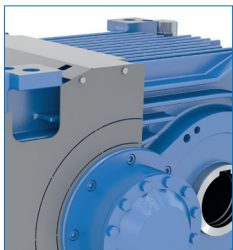
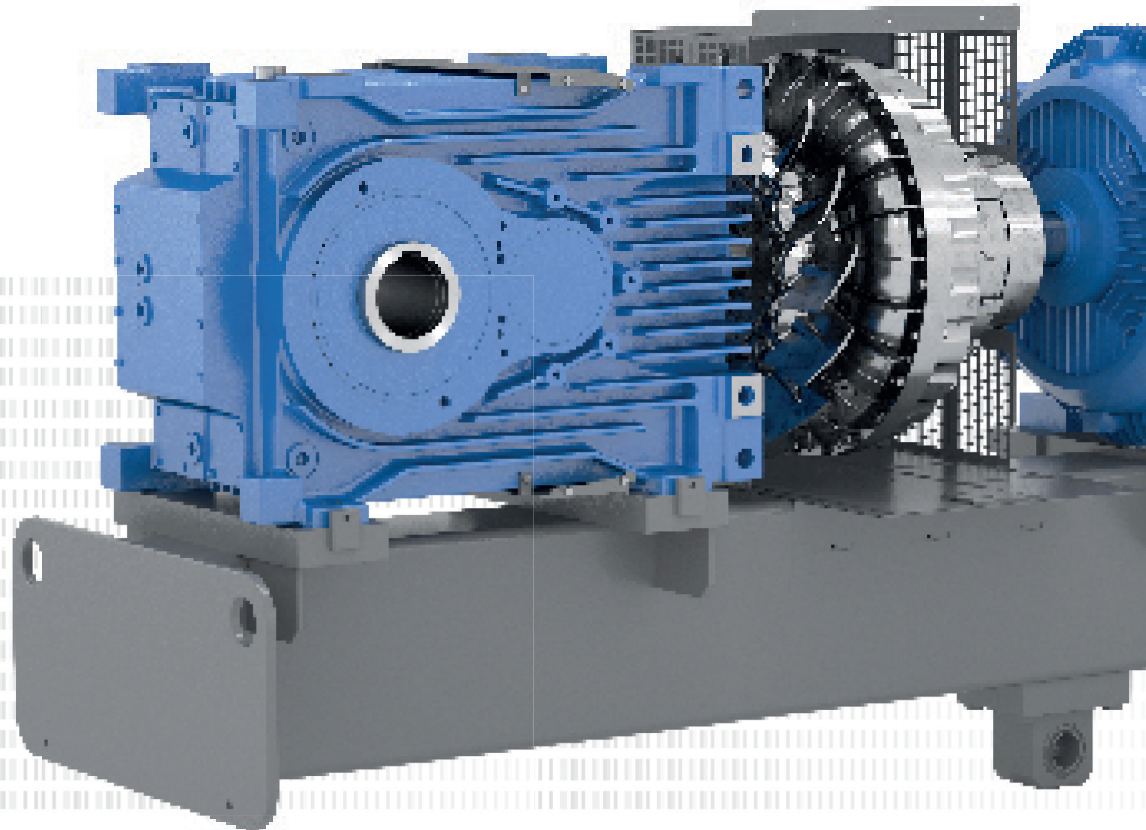

Housing

- ▶ UNICASE housing, one-piece housing design
- ▶ Efficient cooling fin geometry
- ▶ Optimised strength and rigidity
- ▶ Special high-precision housing production
- ▶ High-precision shaft bearings



Gearing

- ▶ Developed according to international standards
- ▶ Case-hardened and hard finished
- ▶ In-house quality production
- ▶ Noise-optimised bevel gears

Complete drive system package

Fully assembled and aligned, including protective covers and monitoring systems

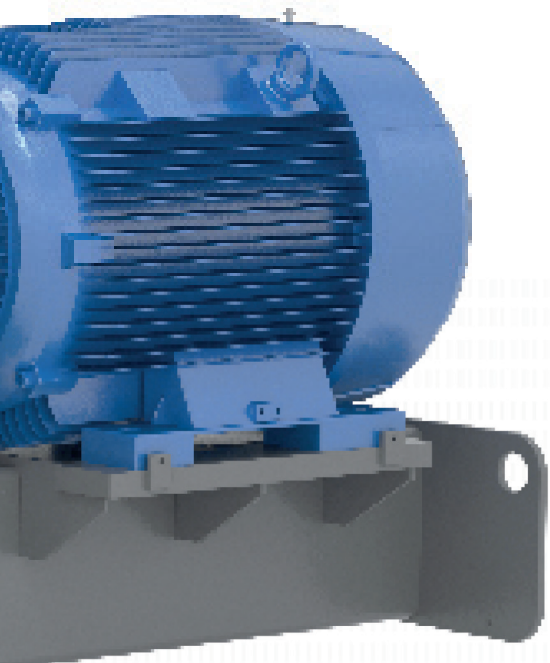

Options



Drive coupling types



IEC/NEMA adapter



Output shafts



Backstop

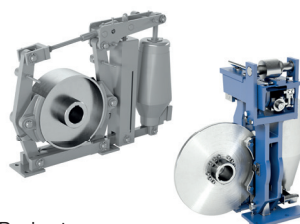

Brake types



Auxiliary drive unit

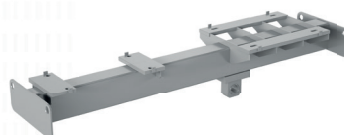

Mounting Base



Motor

Sealing systems

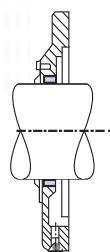

Standard Input
(One sealing ring and one gamma ring seal)

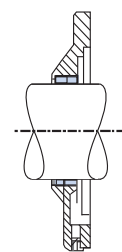

Standard Output
(Two shaft sealing rings)

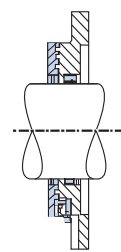

Taconite F Input/Output
(Grease-lubricated labyrinth seal, re-greaseable)

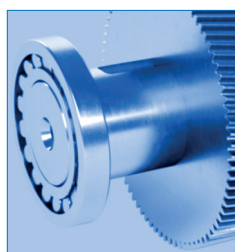

Roller bearings

- ▶ High quality roller bearings from brand manufacturers
- ▶ Reduced friction roller bearings
- ▶ Long-life roller bearings

MAXXDRIVE® XT Right-Angle Gear Units

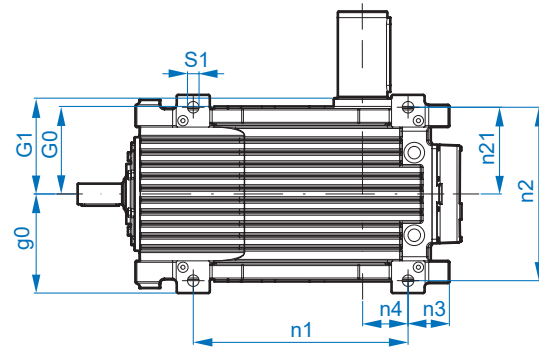
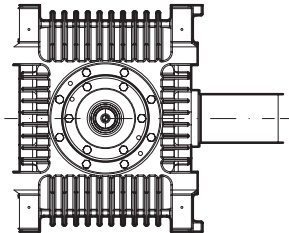
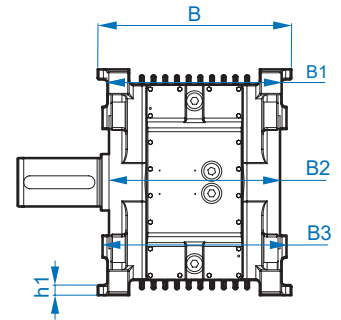
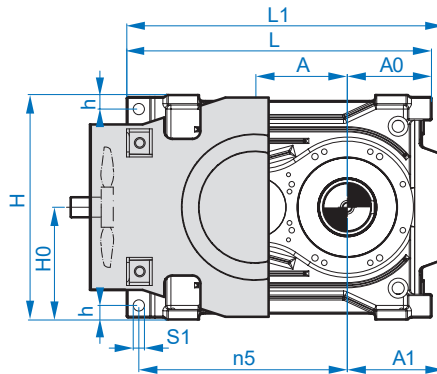
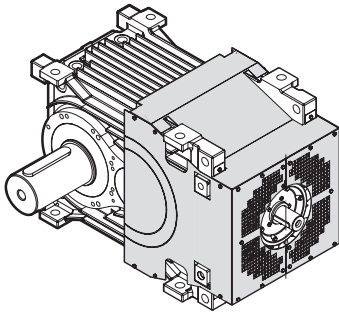

Overall dimensions

Typ	A	A1	A0	g0	G0	G1	h	h1	H	H0	L	L1	B	B1	B2	B3
SK 5217	228	239.5	210	240	216	232	35	25	560	280	760	790	480	432	424	456
SK 6217	268	270	260	240	216	232	35	30	630	315	850	860	480	432	424	456
SK 7217	270	275.5	267	260	241	273	35	35	630	315	912	921	520	482	495	520
SK 8217	294	291.5	283	260	241	273	35	35	670	335	952	961	520	482	495	520
SK 9217	325	321	330	318	303	344	55	45	720	360	1120	1111	636	606	605	620
SK 10217	358	337	352	318	303	343	55	45	790	395	1235	1220	636	606	605	620
SK 11217	384	371.5	366	393	378	410	46	55	830	415	1340	1346	786	710	700	770

Holes/hole spacings

Typ	S1	n1	n2	n21	n3	n4	n5
SK 5217	28	520	420	210	100	110	520
SK 6217	28	585	420	210	122.5	137.5	560
SK 7217	28	640	470	235	127	140	611
SK 8217	28	685	470	235	125	158	635
SK 9217	35	790	575	287.5	155	175	742.5
SK 10217	35	875	575	287.5	177	175	830.5
SK 11217	42	965	700	350	186	180	933

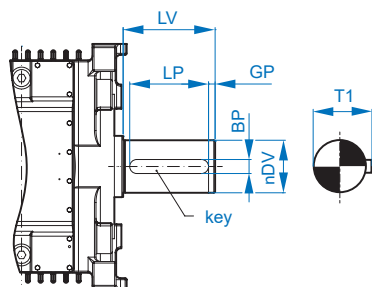

Solid output shaft

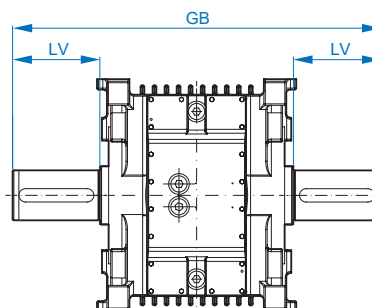

Double solid output shaft

Hollow shaft

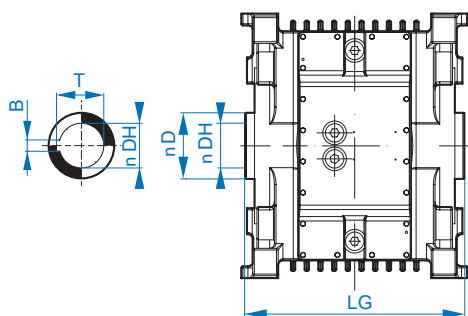

Solid input shaft

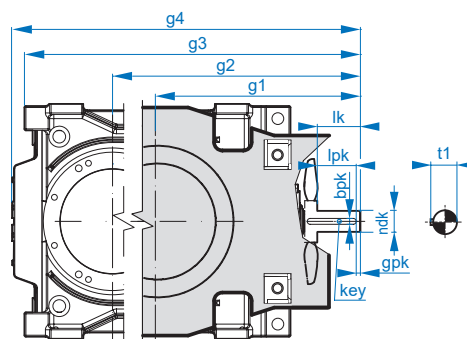

Solid output shaft

Typ	\emptyset DV	LV	LP	BP	GP	T1	Parallel key
SK 5217	120	210	180	32	15	127	32 x 18 x 180
SK 6217	120	210	180	32	15	127	32 x 18 x 180
SK 7217	140	250	200	36	25	148	36 x 20 x 200
SK 8217	140	250	200	36	25	148	36 x 20 x 200
SK 9217	160	300	260	40	20	169	40 x 22 x 260
SK 10217	160	300	260	40	20	169	40 x 22 x 260
SK 11217	170	300	260	40	20	179	40 x 22 x 260

Double solid output shaft

LV	GB
210	884
210	884
250	1045
250	1045
300	1286
300	1286
300	1420

Hollow shaft

\emptyset D	\emptyset DH ^{H7}	LG	B	T
140	105	464	28	111.4
140	105	464	28	111.4
160	125	545	32	132.4
160	125	545	32	132.4
220	160	686	40	169.4
220	160	686	40	169.4
230	170	820	40	179.4

Solid input shaft

Type	i_N	g^1	g^2	g^3	g^4	\emptyset dk	l_k	l_{pk}	b_{pk}	t_1	g_{pk}	Parallel key
SK 5217	6.14 – 22.91	462	690	900	929.5	50	74	64.0	14	53.5	10.0	14 x 9 x 90
SK 6217	6.15 – 22.50	462	730	990	1000.0	50	74	64.0	14	53.5	10.0	14 x 9 x 90
SK 7217	16.06 – 17.94	534	836	1101	1111.05	50	55	45.0	20	53.5	10.0	14 x 9 x 90
	6.37 – 13.20	564				70	85	77.5		7.5		
SK 8217	15.86 – 20.44	536	860	1143	1151.5	50	55	45.0	20	53.5	10.0	20 x 12 x 125
	6.30 – 13.33	566				70	85	77.5		7.5		
SK 9217	16.18 – 18.14	652	1006	1337	1320.0	70	91	83.5	22	85.0	7.5	22 x 14 x 140
	6.42 – 13.47	682				80	121	106		15.0		
SK 10217	15.76 – 18.17	712	1070	1452	1407.0	70	91	83.5	22	85.0	7.5	22 x 14 x 140
	6.26 – 13.74	742				80	121	106		15.0		
SK 11217	16.84 – 18.44	822	1236	1602	1607.5	80	135	120	28	85.0	15.0	28 x 16 x 180
	6.69 – 13.35	852				100	200	155				

The MAXXDRIVE® series is the dependable member of the NORD product family for high torques. With an extensive range of modular products NORD provides many technically and commercially optimised drive solutions. Especially in the field of agitator drive systems, tailored solutions can be offered through the combination of the many standardised variants and options.

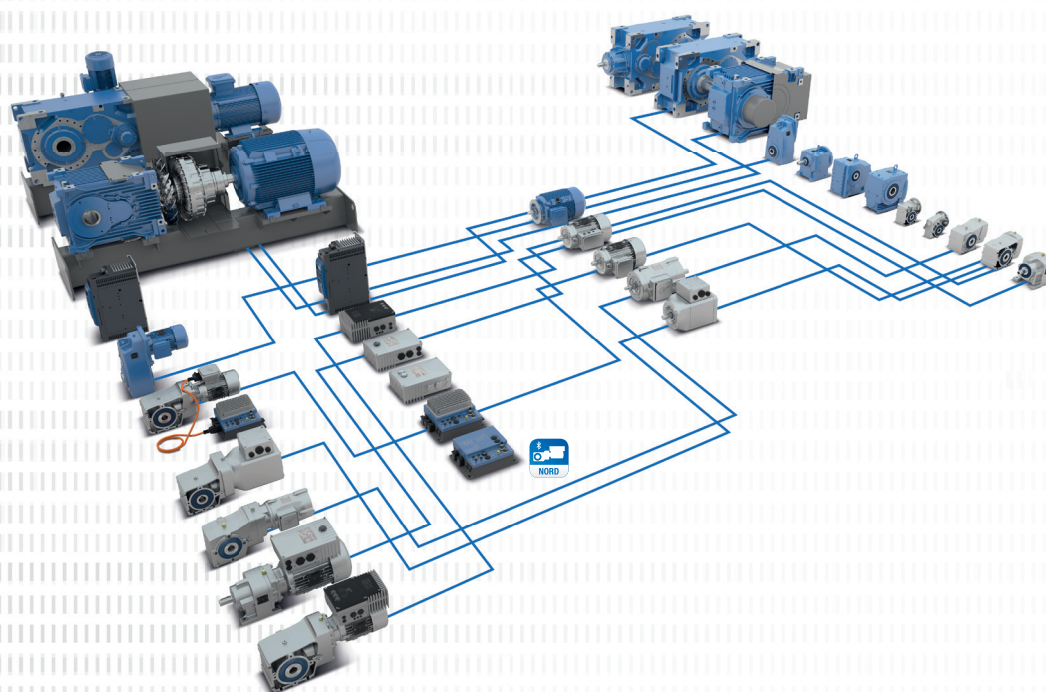

NORD DRIVESYSTEMS Product portfolio

- ▶ Complex drive systems from modular components
- ▶ Great depth of production
- ▶ High availability
- ▶ Global production network
- ▶ Short delivery times for stock components and spare parts
- ▶ Highest product quality at all locations
- ▶ ATEX version also available
- ▶ myNORD customer portal for online configuration, prices, delivery times and orders
- ▶ 24/7 dependable partner for engineering, production, installation and service

EN

Headquarters
Getriebebau NORD GmbH & Co. KG
Getriebebau-Nord-Str. 1
22941 Bargteheide, Deutschland
T: +49 45 32 / 289 0
F: +49 45 32 / 289 22 53
info@nord.com